

Product data sheet, January 2020

Makrolon® multi UV 7M/16-28

Multiwall polycarbonate sheet



I Line
Innovative

Your benefits:

- extremely heat-insulating
- high stiffness
- good load bearing capacity



Makrolon® multi UV 7M/16-28 is a polycarbonate sheet of 16 mm thickness, with a M-structure for enhanced stiffness. It combines good load bearing properties, good thermal insulation, light transmission and excellent weather resistance. The sheet is lightweight, impact resistant and easy to install.

Makrolon® multi UV 7M/16-28 is ideal for flat glazing applications.

- conservatories
- industrial glazing, sports halls
- skylights, northlight glazing
- roofing, cladding

The sheets are produced with a coextruded UV-protective layer, which is homogeneously fused with the sheet material. This UV-protected side must be installed facing upwards/outwards. It provides **Makrolon® multi UV** with a highly effective protection against weathering, guaranteed for 10 years.

On request:

IQ-Relax

Makrolon® multi IQ-Relax are opal white sheets, which dramatically reduce the heat of the sunlight, allowing the visible light to pass through. More light, less heat!

TECHNICAL DATA (TYPICAL VALUES)

Area weight	2.7 kg/m ²	
Sheet width	980, 1200 mm	
Possible delivery lengths	2,000 to 7,000 mm	
Light transmittance τ_{D65} (UV-absorbing)	white 1149: IQ-Relax:	ca. 34 % ca. 32 %
Total energy transmission g	white 1149: IQ-Relax:	ca. 35 % ca. 31 %
Heat transfer coefficient U_g ⁽²⁾	1.72 W/m ² K (vertical application) 1.81 W/m ² K (horizontal application)	
Coefficient of thermal expansion α	0.065 mm/m °C	
Possible expansion due to heat and moisture	3 mm/m	
Max. service temperature without load	120°C	
Fire rating ⁽¹⁾		
• Europe	white 1149 IQ-Relax	B-S1, d0 (EN13501-1) B-S1, d0 (EN13501-1)

⁽¹⁾ Fire certificates are limited in time and scope, always check if the mentioned certificate is valid for the purchased Polycarbonate sheet type at the date of delivery. Polycarbonate sheets may change their fire behavior due to ageing and weathering. The indicated fire rating was tested on new / unweathered Product in accordance with the indicated fire classification standards.

⁽²⁾ Heat transfer coefficient U_g according to EN ISO 10077-2

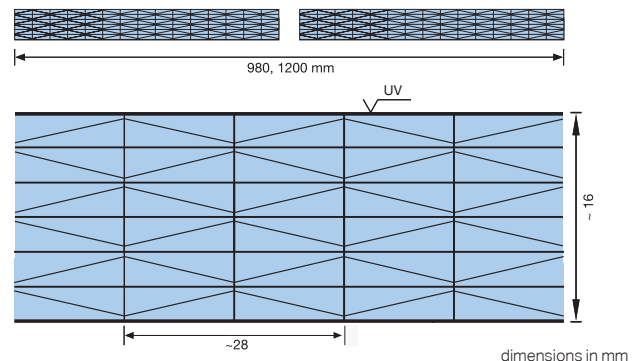

Makrolon® multi UV 7M/16-28

Multiwall polycarbonate sheet



Ideas, innovative, intelligent, interesting... Exolon Group i-line represents the next generation of quality products. This seal guarantees innovative and intelligent first-class solutions at all times for a multitude of requirements.

When using **Makrolon® multi UV 7M/16-28** in roof or wall installations, the forces exerted by snow and wind loads must be absorbed by a suitable substructure. We recommend implementing the support distance indicated in the diagram for the respective loads.

The diagram shows the load-bearing capacity of **Makrolon® multi UV 7M/16-28** (supported on all sides, rebate depth ≥ 20 mm) with a standard profile on the longitudinal sides. The load-bearing curves enable the user to calculate the actual load-bearing characteristics of the multi-wall sheets in their support construction.

If the rebate depth is smaller, the support distances should be reduced in accordance with the relevant load. For wind forces alone, the loads are permitted to be multiplied by 1.1.

Load bearing characteristics (determination):

The component resistance (limit state of load-bearing capacity) of **Makrolon® multi UV 7M/16-28** has been defined in accordance with the European guideline ETAG 010 regarding practical tests. The characteristic values identified were calculated on the longitudinal sides by considering the chocking effect (standard profiles). The results were partially applied to other widths using simplified, conservative models. The loads were applied as uniformly distributed linear loads, i.e. loads such as snow acting perpendicular to the sheet.

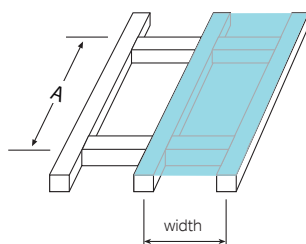

The values are reference values calculated by an independent and notified institute through tests on actual systems. Adequate safety margins must be observed in addition to these values. The margins are to be assessed on a case-by-case basis.

In general, experience has proven that a safety factor of 1.3 is adequate with regard to the measured resistance values. This safety factor is included in the load tables and diagram.

These statements do not replace the specified national certificates, e.g. building inspectorate approval (Bauaufsichtliche Zulassung Germany), Avis Techniques (France), etc.

*Further information can be obtained on request

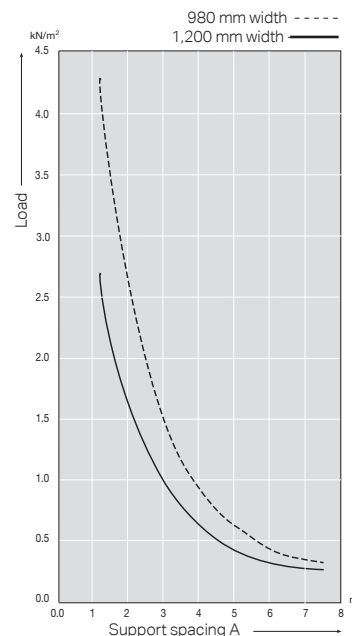

Load	kN/m ²	0.75	1.0	1.25	1.5	2.0	Width in mm
Length or support	m	4.5	4.0	3.5	3.0	2.5	980
spacing A	m	3.7	3.0	2.6	2.2	1.7	1,200

Exolon Group also produces solid sheets in polycarbonate (Makrolon® GP) and in polyester (Vivak® and Axpet®). For more information, take a look at www.exolongroup.com.



Exolon Group GmbH
 Rommerskirchener Str. 21
 50259 Pulheim
 Germany
www.exolongroup.com
sales@exolongroup.com

The manner in which you use and the purpose to which you put and utilize our products, technical assistance and information (whether verbal, written or by way of production evaluations), including any suggested formulations and recommendations, are beyond our control. Therefore, it is imperative that you test our products, technical assistance, information and recommendations to determine to your own satisfaction whether our products, technical assistance and information are suitable for your intended uses and applications. This application-specific analysis must at least include testing to determine suitability from a technical as well as health, safety, and environmental standpoint. Such testing has not necessarily been done by Exolon Group. Unless we otherwise agree in writing, all products are sold strictly pursuant to the terms of our standard conditions of sale which are available upon request. All information and technical assistance is given without warranty or guarantee and is subject to change without notice. It is expressly understood and agreed that you assume and hereby expressly release us from all liability, in tort, contract or otherwise, incurred in connection with the use of our products, technical assistance, and information. Any statement or recommendation not contained herein is unauthorized and shall not bind us. Nothing herein shall be construed as a recommendation to use any product in conflict with any claim of any patent relative to any material or its use. No license is implied or in fact granted under the claims of any patent.

Makrolon® is a registered trademark, owned and licensed by Covestro Group